

TYPICAL STREET SECTION
LOCAL STREET-RESIDENTIAL/RURAL WITH MEDIAN
NOT TO SCALE

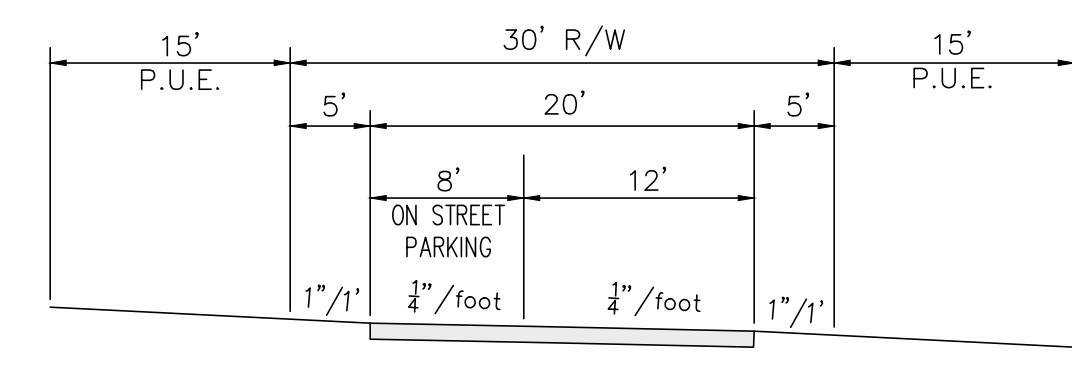

TYPICAL STREET SECTION
LOCAL STREET-ONE WAY
NOT TO SCALE

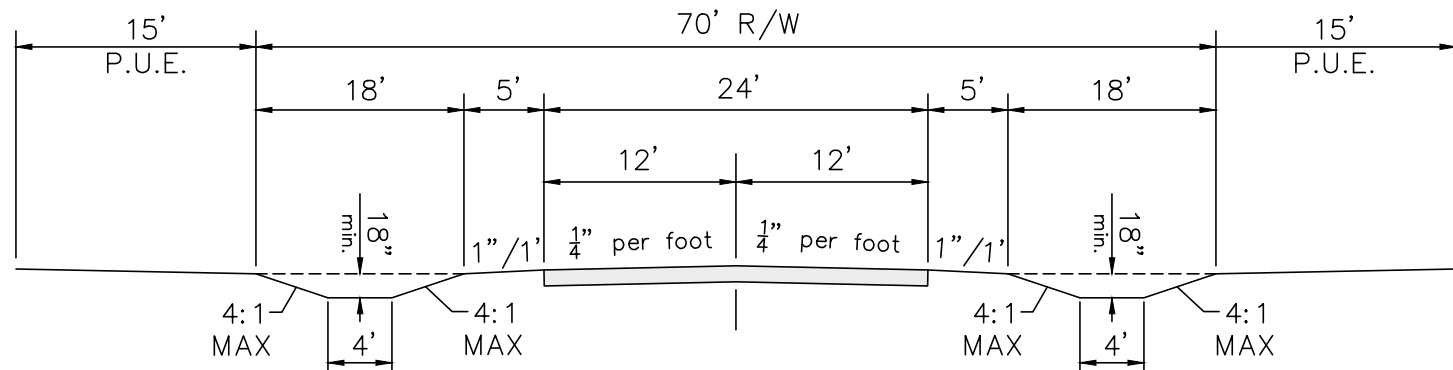

TYPICAL STREET SECTION
LOCAL STREET-RESIDENTIAL/RURAL
NOT TO SCALE

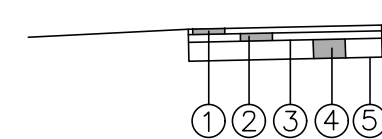

① ITEM 448 - 1.5" ASPHALT CONCRETE, SURFACE COURSE, TYPE 1
 ② ITEM 448 - 2" ASPHALT CONCRETE, INTERMEDIATE COURSE, TYPE 1
 ③ ITEM 407 - TACK COAT
 ④ ITEM 301 - 5" BITUMINOUS AGGREGATE BASE
 ⑤ ITEM 204 - COMPACTED SUBGRADE

TYPICAL PAVEMENT SECTION
NOT TO SCALE

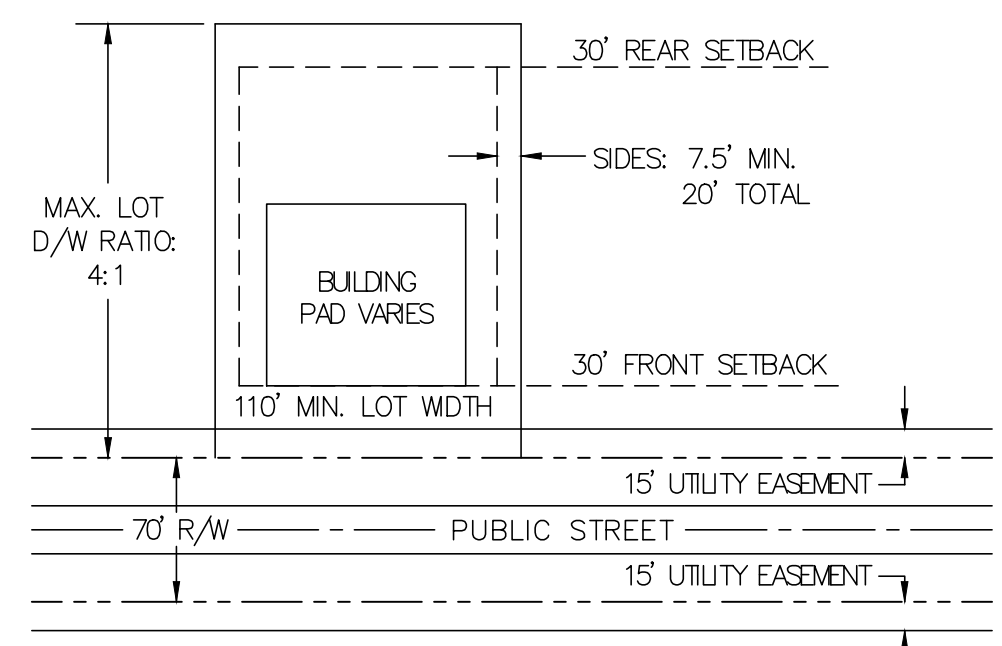

TYPICAL LOT SECTION
CUSTOM LOTS
NOT TO SCALE

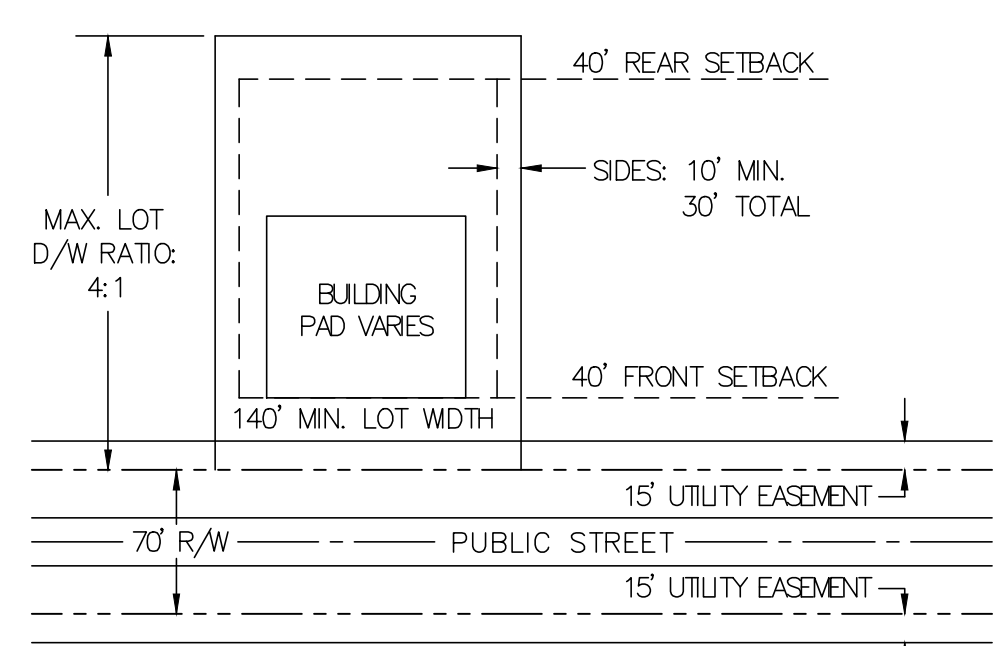

TYPICAL LOT SECTION
DESIGN/BUILD LOTS
NOT TO SCALE

Legend:

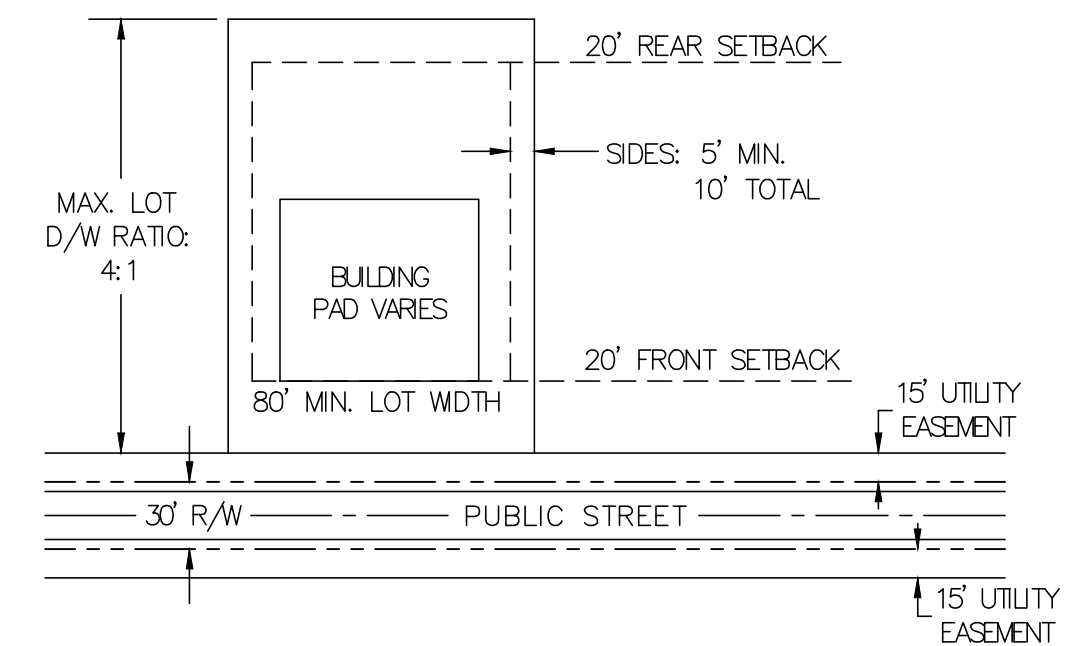

TYPICAL LOT SECTION
PARK SIDE LOTS/
EXISTING FARMHOUSE
NOT TO SCALE

ITEM	DESCRIPTION OF REVISIONS	DATE	BY

CREEK SONG
 PLANNED UNIT DEVELOPMENT
 PUD STAGE 1
 TURTLE CREEK TOWNSHIP
 WARREN COUNTY, OH
 TYPICAL LOT/ROADWAY SECTIONS

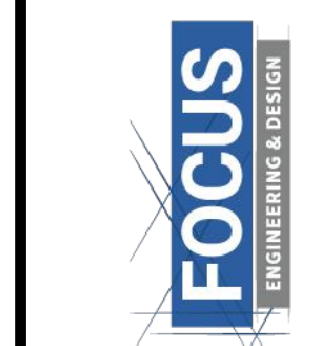

DRAWN BY: JWR
 APPROVED BY: JWR
 DRAWING NAME:
 DATE: 10-26-2018
 SHEET NO.: 3 OF 6